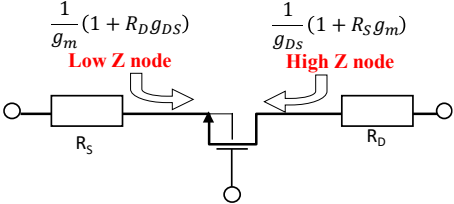

Name: _____

Place N°: _____

ANALOG IC – Final Exam - 01/26/2023 (Part 1)

Saturation Voltage	$V_{DS,sat} = V_{GS} - V_{T0} = V_{ov}$	$V_{D,sat} = V_G - V_T$
Saturation + SI: $V_D > V_{Dsat}$	$I_D = \frac{\beta}{2} (V_{GS} - V_T)^2$ $\beta = k_p \frac{W}{L}; g_m = \beta V_{ov} = \sqrt{2\beta I_D}$	$g_{DS} = r_o^{-1} = \frac{\partial I_D}{\partial V_{DS}} = \frac{I_D}{L \cdot U_a} \ll g_m$ $C_{GS} \approx W \cdot L(2/3) C_{ox}; C_{GD} \ll C_{GS}$
Inversion Factor I_F $U_T = kT/q = 26$ $mV@300$ k	$I_F = \frac{I_D}{I_s} = \frac{I_D}{2n\mu C_{ox} \frac{W}{L} U_T^2}$ $\frac{g_m}{I_D} = \frac{1}{nU_T} \cdot \frac{1}{1 + \sqrt{4I_F + 1}}$	

Given the following OTA with

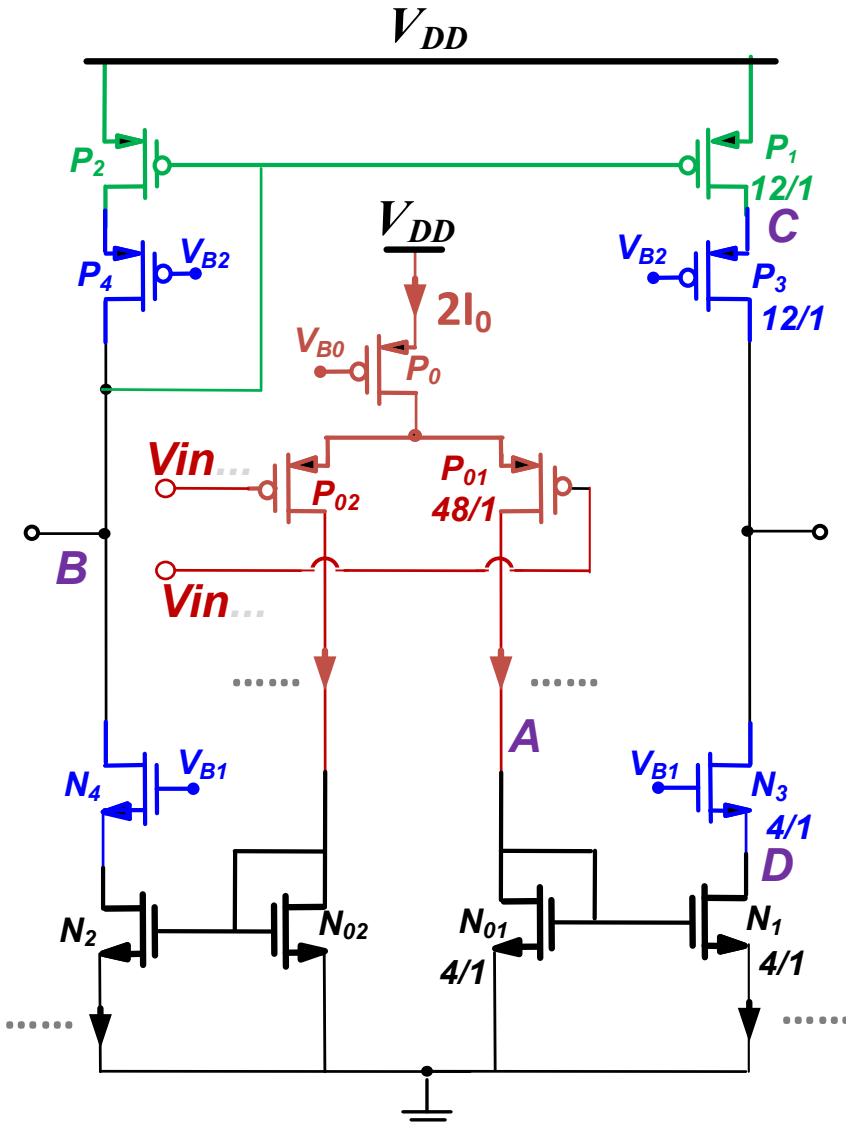

- $V_{DD} = 1.8$ V, $V_{Tn} = 0.4$ V, $V_{Tp} = 0.5$ V.
- $C_{ox} = 8$ fF/ μm^2 , $C_{ov} \sim 0$ fF/ μm .
- $I_0 = 10$ μA , $C_L = ?$ pF.
- For (P01,P02): $I_F = 2$; $g_m = 200$ $\mu A/V$;
 $g_{DS} = 1$ $\mu A/V$.
- Other transistors: $I_F = 10$; $V_{ov} = 0.2$ V;
 $g_m = 100$ $\mu A/V$; $g_{DS} = 1.5$ $\mu A/V$.

*Give only the final-results (i.e. the theoretical expressions and their values).
For each parameter, indicate the corresponding transistor (e.g. $V_{ov,p1}$ or $g_{m,N3}$)*

1. Operation and voltage headroom (~10mn)

- Show on the schematic by **LZ** and **HZ** the low impedance nodes and the high impedance nodes.
Deduce **the output node** and put C_L on it.
 - Give the **DC current** of each branch on the schematic.
 - Show the inverting (**Vin-**) and non-inverting (**Vin+**) inputs on the schematic.
 - Place a frequency compensation (**Rc, Cc**) for stability if required. Justify briefly your choice:
-

2. DC and ac characterization: Give the expression and the value of (~ 50 mn)

	Analytical expression	Numeric al value	Guideline
$V_{B1,min}$			<i>for optimal output swing</i>
$V_{B2,max}$			<i>for optimal output swing</i>
$CMIR^+$			<i>common mode</i> $V_{in,max}$
$CMIR^-$			<i>common mode</i> $V_{in,min}$
V_{OUTmax}			<i>output voltage</i> <i>max</i>
V_{OUTmin}			<i>output voltage</i> <i>min</i>
R_A			<i>ac resistance at</i> <i>A</i>
R_B			<i>ac resistance at</i> <i>B</i>

R_C			<i>ac resistance at C</i>
R_D			<i>ac resistance at C</i>
R_{out}			<i>ac resistance at the output</i>
A [dB]			<i>gain at low frequency</i>
f_{N-dom} [Hz]			<i>Non-dominant</i>
f_{dom} [Hz]			<i>dominant pole optimal for stability</i>
C_L			<i>C_L optimal for stability</i>
GBW [Hz]			<i>Gain-bandwidth</i>
Sr [V/μs]			<i>Slew rate</i>
PM			
Stability?			